

VISION™ 2

SPOTLIGHT

TYPE:

PROJECT NAME:



materials:	anodized aluminum frame, AISI 316L stainless steel stake			
light:	direct			
light sources:				
<i>Color temperature</i>	<i>Optics</i>	<i>LED light source</i>		<i>lm source</i>
<i>/W</i>	<i>/18 /40 /60</i>	5,9W	17V 350mA	885lm 4000K
<i>/WW</i>	<i>/18 /40 /60</i>	5,9W	17V 350mA	836lm 3000K
<i>/XW</i>	<i>/18 /40 /60</i>	5,9W	17V 350mA	800lm 2700K
IP grade:	IP66			
net weight:	0,50 Kg			
finishes:	.34 corten painted .39 anthracite painted .45 anodized aluminum			
symbols:				

Dimensions

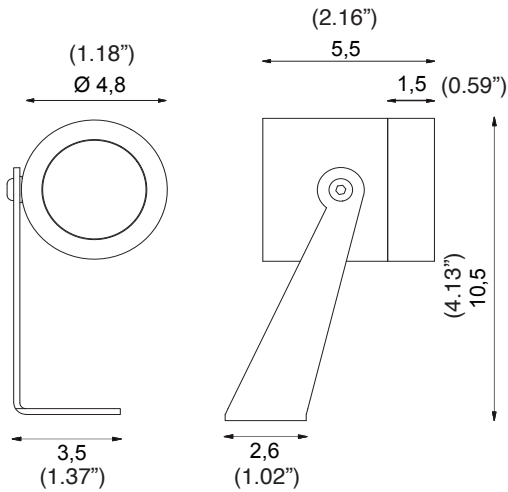

Accessories



0247 stake



0243 IP connector

ORDERING INFO

L674530

Model (Order Code)	Structure Finishes	Optic	LED	Accessories	Remote Driver Options (350mA)
<input type="radio"/> L674530 5.9W	<input type="radio"/> 34: Corten Painted <input type="radio"/> 39: Anthracite Painted <input type="radio"/> 45: Anodized Aluminum	<input type="radio"/> 18: 18° <input type="radio"/> 40: 40° <input type="radio"/> 60: 60°	<input type="radio"/> XW: 2700K <input type="radio"/> WW: 3000K <input type="radio"/> W: 4000K	<input type="radio"/> 0247: Stake <input type="radio"/> 0243: IP Connector	<input type="radio"/> 120V On/Off (Min 1 Max 2 Fixtures) <input type="radio"/> 120V Phase Dimming (Min 2 Max 4) <input type="radio"/> 120V 0-10V Dimming (Min 2 Max 4) <input type="radio"/> 277V 0-10V Dimming (Min 2 Max 4)

SPECIFICATION SHEET



LEDOLOGY®

A **Luminart** BRAND

WWW.LEDOLOGY.COM
Last updated: 02/20/25