

# EVER AND EVER™

## SUSPENSION INSTALLATION SHEET

TYPE:

PROJECT NAME:

**IMPORTANT** - READ CAREFULLY BEFORE INSTALLING FIXTURE. RETAIN THESE INSTRUCTIONS FOR FUTURE REFERENCE. THIS PRODUCT MUST BE INSTALLED IN ACCORDANCE WITH THE NATIONAL ELECTRICAL CODE AND ALL APPLICABLE LOCAL CODES, BY A PERSON FAMILIAR WITH THE CONSTRUCTION AND OPERATION OF THE PRODUCT, AND THE HAZARDS INVOLVED. PROPER GROUNDING IS REQUIRED FOR SAFETY.

### SINGLE UNIT INSTALLATION (LENGTHS FROM 2' TO 8')

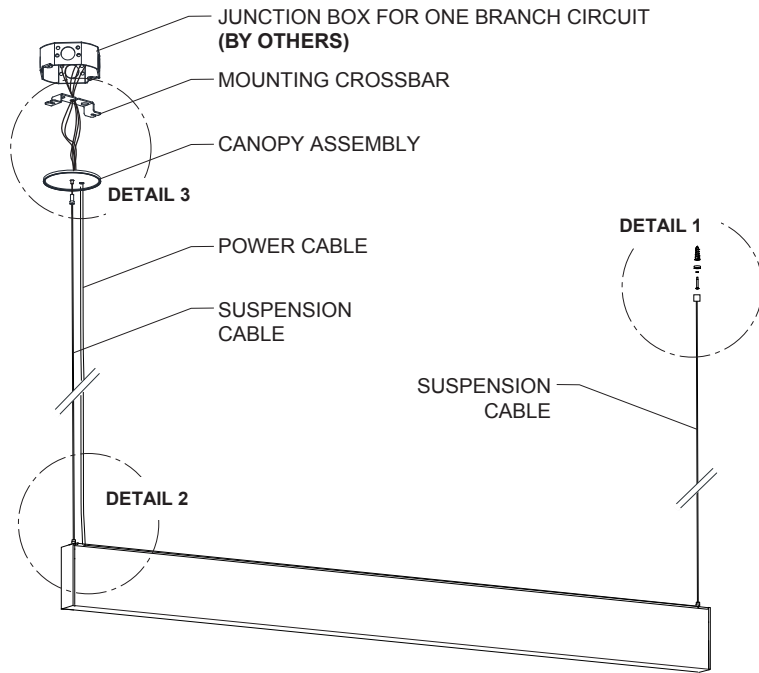

Nominal length	Actual length	Anchor points mounting distance (*)
02	2'-1 <sup>1</sup> / <sub>8</sub> "	24"
03	3'-1 <sup>1</sup> / <sub>8</sub> "	36"
04	4'-1 <sup>1</sup> / <sub>8</sub> "	48"
06	6'-1 <sup>1</sup> / <sub>8</sub> "	72"
08	8'-1 <sup>1</sup> / <sub>8</sub> "	96"
12	12'-1 <sup>1</sup> / <sub>8</sub> "	96"+48"
16	16'-1 <sup>1</sup> / <sub>8</sub> "	96"+96"
24	24'-1 <sup>1</sup> / <sub>8</sub> "	96"+96"+96"

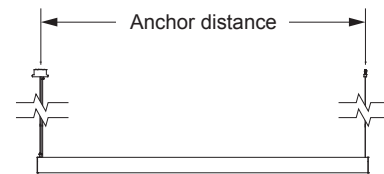

The luminaires runs can be manufactured in most lengths with 12" increments. Contact the factory for precise lengths and anchoring point details.

### DETAIL 1 - ANCHOR INSTALLATION

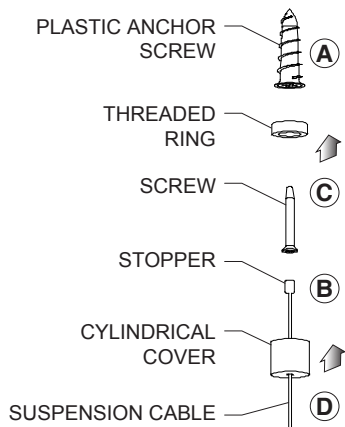

- A** - PLACE PLASTIC ANCHOR SCREWS IN CEILING AT THE REQUIRED DISTANCE AS SHOWN.
- B** - PASS SUSPENSION CABLE THROUGH CYLINDRICAL COVER.
- C** - PASS SCREW THROUGH THREADED RING AND SECURE SCREW INTO PLASTIC ANCHOR SCREW.
- D** - FASTEN CYLINDRICAL COVER TO THREADED RING.

SPECIFICATION SHEET

**LEDOLOGY®**

WWW.LEDOLOGY.COM

A **Luminart** BRAND

# EVER AND EVER™

## SUSPENSION INSTALLATION SHEET

TYPE:

PROJECT NAME:

### DETAIL 2 - MECHANICAL ASSEMBLY

NOTE: UNITS WITH 2 CABLE GRIPPERS MUST BE FIRST TO BE INSTALLED

**E** - REMOVE PROTECTIVE ALUMINIUM COVER AND DIFFUSER (IF NEEDED).

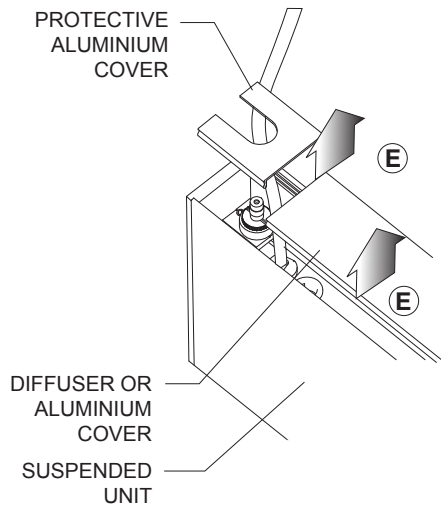

**F** - UNSCREW CABLE GRIPPER SECURITY NUT TO RELEASE CABLE GRIPPING SYSTEM. DO NOT COMPLETELY REMOVE THE SCREW.

**G** - RAISE SUSPENDED UNIT UP TO PREVIOUSLY INSTALLED SUSPENSION CABLES.

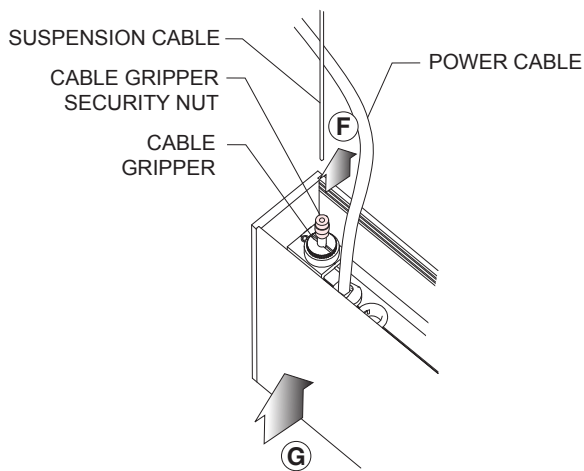

**H** - INTRODUCE SUSPENSION CABLE THROUGH SECURITY NUT AND THROUGH CABLE GRIPPER.

**I** - SET THE UNIT TO THE APPROPRIATE HEIGHT AND SCREW BACK SECURITY NUT. THIS WILL PREVENT FIXTURE FROM ACCIDENTALLY FALLING.

**J** - TRIM OFF THE UNNECESSARY SUSPENSION CABLE END. REPLACE PROTECTIVE COVER. BOTH SUSPENSION CABLE AND POWER CABLE MUST GO THROUGH U-TYPE OPENING.

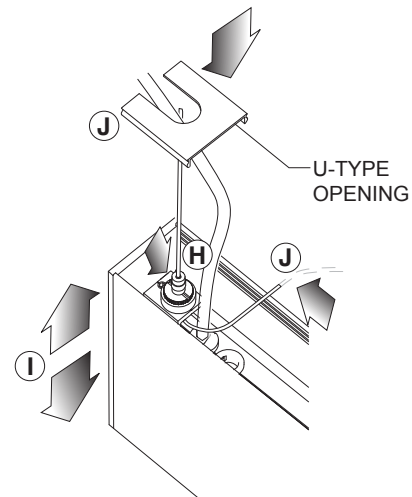

SPECIFICATION SHEET

LEDOLOGY®

WWW.LEDOLOGY.COM

A Luminart® BRAND

# EVER AND EVER™

## SUSPENSION INSTALLATION SHEET

**TYPE:**

**PROJECT NAME:**

### FEED INFORMATION

MAIN FEED IS LOCATED AT THE BEGINNING OF THE FIRST SECTION. FOR LONGER FIXTURES SUBSEQUENT FEEDS ARE NEEDED. REFER TO THE TABLE FOR MAXIMUM LENGTH PER SINGLE FEED. THE FEEDS ARE LOCATED AT THE BEGINNING OF THE NEXT FOLLOWING SECTION, EXCEPT FOR THE LAST FEED WHICH IS LOCATED AT THE END OF THE LAST SECTION OF THE FIXTURE.

Maximum fixture length per single feed (nominal length) :

	LENGTH	
	1 circuit	2 circuits
NO DIM.	16'	32'
0-10V	16' (D10)	32' (2D0)
BUS	22' (D2B)	44' (2DB)

### DETAIL 3 - CANOPY INSTALLATION AND ELECTRICAL (using one branch Circuit)

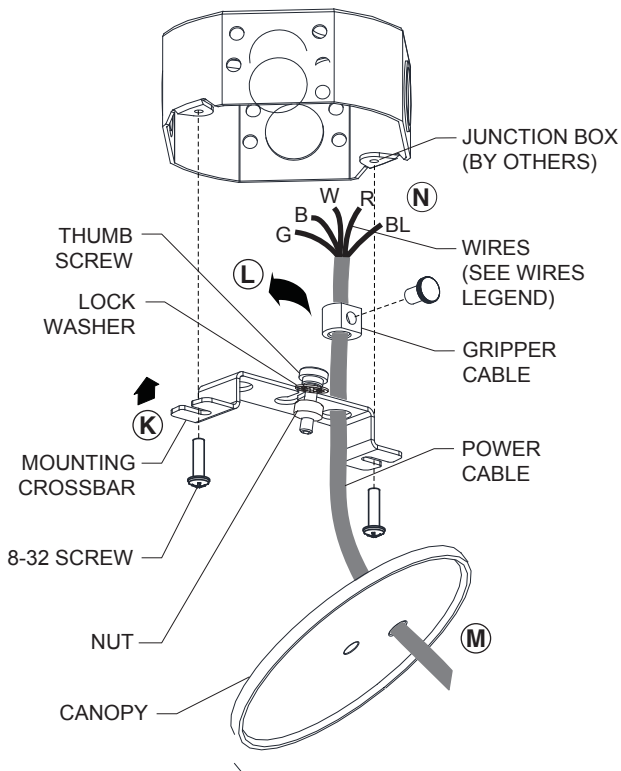

- K** - INSTALL MOUNTING CROSSBAR USING 8-32 SCREWS.
- L** - PASS THUMB SCREW INTO THE MOUNTING CROSSBAR KEY HOLE W/LOCK WASHER ON TOP. HOLD SUSPENSION CABLE DOWN IN POSITION AND SECURE WITH THE PROVIDED NUT.
- M** - INTRODUCE POWER CABLE THROUGH CANOPY, PASS IT THROUGH MOUNTING CROSSBAR HOLE, ADJUST LENGTH AND TIGHTEN IT USING CABLE GRIPPER TO LOCK POSITION.
- N** - MAKE NECESSARY ELECTRICAL CONNECTIONS. (REFER TO WIRES LEGEND). FOR DIMMING 0-10V AND BUS SUPPLY: WIRES MUST BE RUN THROUGH A SEPARATE KNOCKOUT HOLE WHEN CONNECTING DIMMING CONTROLLER. (REFER TO WIRING DIAGRAM SECTION).
- O** - SECURE CANOPY USING FINISHING SCREW.

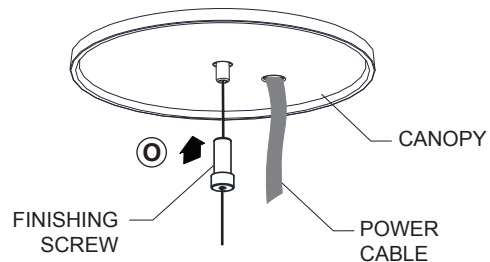

SPECIFICATION SHEET

**LEDOLOGY®**

WWW.LEDOLOGY.COM

A **Luminart** BRAND

# EVER AND EVER™

## SUSPENSION INSTALLATION SHEET

TYPE:

PROJECT NAME:

### WIRING DIAGRAM (using one branch Circuit)

**NO DIMMING WITH 2 CIRCUITS:** Direct and indirect lighting are on separate circuits.

**AC Wiring on the same CANOPY,** subsequent canopies may be needed, refer to feed information section.

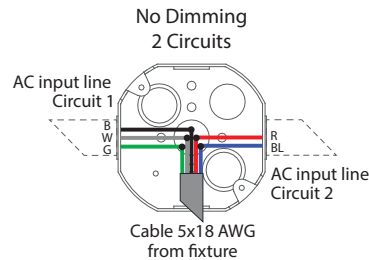
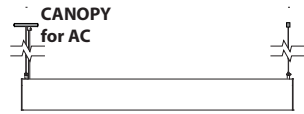

WIRES LEGEND		
SYMBOL	COLOR	DESTINATION
G	Green	Ground, 1 / 2
W	White	Neutral, 1
B	Black	Live, 1
R	Red	Live, 2
BL	Blue	Neutral, 2

**DIMMING WITH 1 CIRCUIT:** Direct and indirect lighting are on the same circuit.

**AC and Dimming wiring on the same CANOPY,** subsequent canopies may be needed, refer to feed information section.

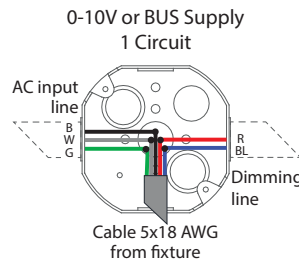
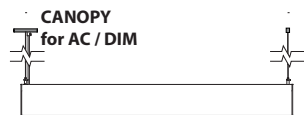

WIRES LEGEND		
SYMBOL	COLOR	DESTINATION
G	Green	Ground
W	White	Neutral
B	Black	Live
R	Red	DIM (+) or E1
BL	Blue	DIM (-) or E2

**DIMMING WITH 2 CIRCUITS** Direct and indirect lighting are on separate circuits.



**AC Wiring on CANOPY for AC,** subsequent feeds may be needed, refer to feed information section.

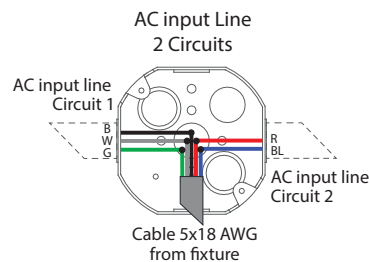

WIRES LEGEND		
SYMBOL	COLOR	DESTINATION
G	Green	Ground, 1 / 2
W	White	Neutral, 1
B	Black	Live, 1
R	Red	Live, 2
BL	Blue	Neutral, 2

**Dimming wiring on CANOPY for DIM.**

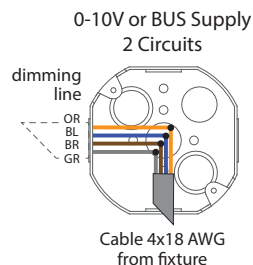

WIRES LEGEND		
SYMBOL	COLOR	DESTINATION
OR	ORANGE	DIM (+) or E1, 1
BL	BLUE	DIM (-) or E2, 1
BR	BRUN	DIM (+) or E1, 2
GR	GRAY	DIM (-) or E2, 2

SPECIFICATION SHEET

LEDOLOGY®

WWW.LEDOLOGY.COM

A Luminart BRAND

# EVER AND EVER™

## SUSPENSION INSTALLATION SHEET

TYPE:

PROJECT NAME:

### IN-LINE UNITS INSTALLATION (LENGTHS FROM 9' AND MORE)

**P** - ELEVATE IN-LINE UNIT AND INSTALL SUSPENSION CABLE FOLLOWING PREVIOUS PAGE STEPS.

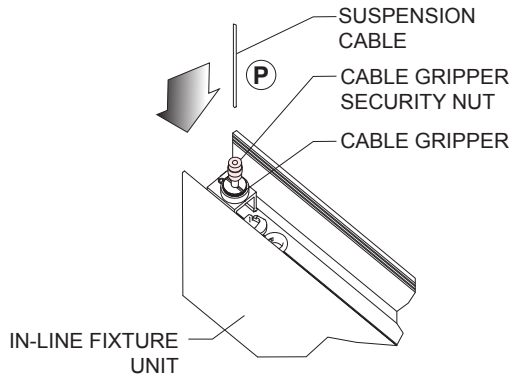

**Q** - REMOVE DIFFUSER AND UNSCREW DOWNLIGHT LED MODULE SCREWS FROM IN-LINE UNIT. DISCONNECT AND REMOVE LED MODULE.

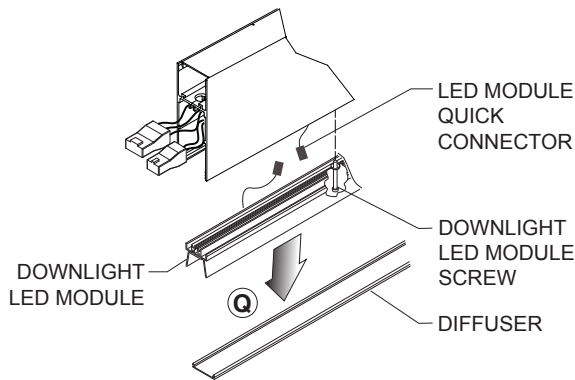

**R** - BEFORE THE INSTALLATION OF THE IN-LINE UNIT. MAKE SURE THAT THE MECHANICAL JOINT ON THE PRECEDENT SECTION IT IS CORRECTLY CENTERED IN ORDER TO AVOID LIGHT LEAK.

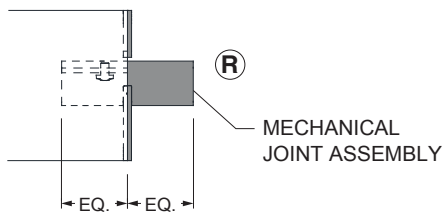

**S** - JOIN QUICK CONNECTORS\*.

**T** - SLIDE IN-LINE UNIT ONTO STRAIGHT JOINT ASSEMBLY IN ORDER TO CONNECT BOTH UNITS. MAKE SURE TO NOT SQUEEZE ANY CABLES.

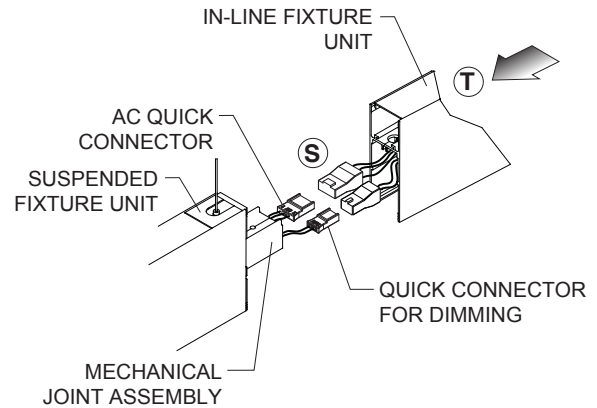

\*USE COLOR-MATCHING CRITERIA TO PLUG QUICK CONNECTORS

**U** - FASTEN IN-LINE UNIT TO STRAIGHT JOINT ASSEMBLY USING PHILLIPS 1/4-20 SCREW. DO NOT OVERTIGHTEN THE SCREWS, OTHERWISE IT WILL CAUSE A SEPARATION BETWEEN THE JOINED EXTRUSIONS.

**V** - CONNECT AND INSTALL LED MODULE INTO POSITION. FASTEN LED MODULE SCREWS AND REINSTALL DIFFUSER.

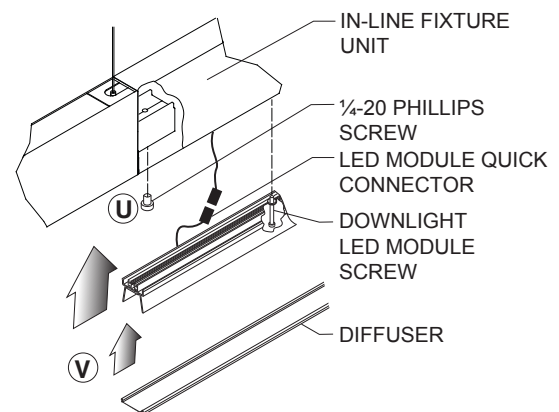

SPECIFICATION SHEET

LEDOLOGY®

WWW.LEDOLOGY.COM

A **Luminart** BRAND